



# **TRI-GLIDE**

**3-Point  
Heavy  
Moving  
Over All  
Types of  
Floors**



**Easily, Safely & Efficiently**

### 3-Point Moving

The Tri-Glide 3-point moving system provides a safe and efficient method for moving heavy objects.

With the rear units kept aligned by use of a spreader bar, the rear dollies can be adjusted from a range of 10" apart to as much as 48" apart. Placing the dollies where support is needed ensures the rear dollies will be kept parallel in order to track properly when moving. Just as the rear wheels of your car follow the front when you turn, so too will the Tri-Glide's rear dollies follow the front. Thus 3-point moving affords the user a wide range of mobility.

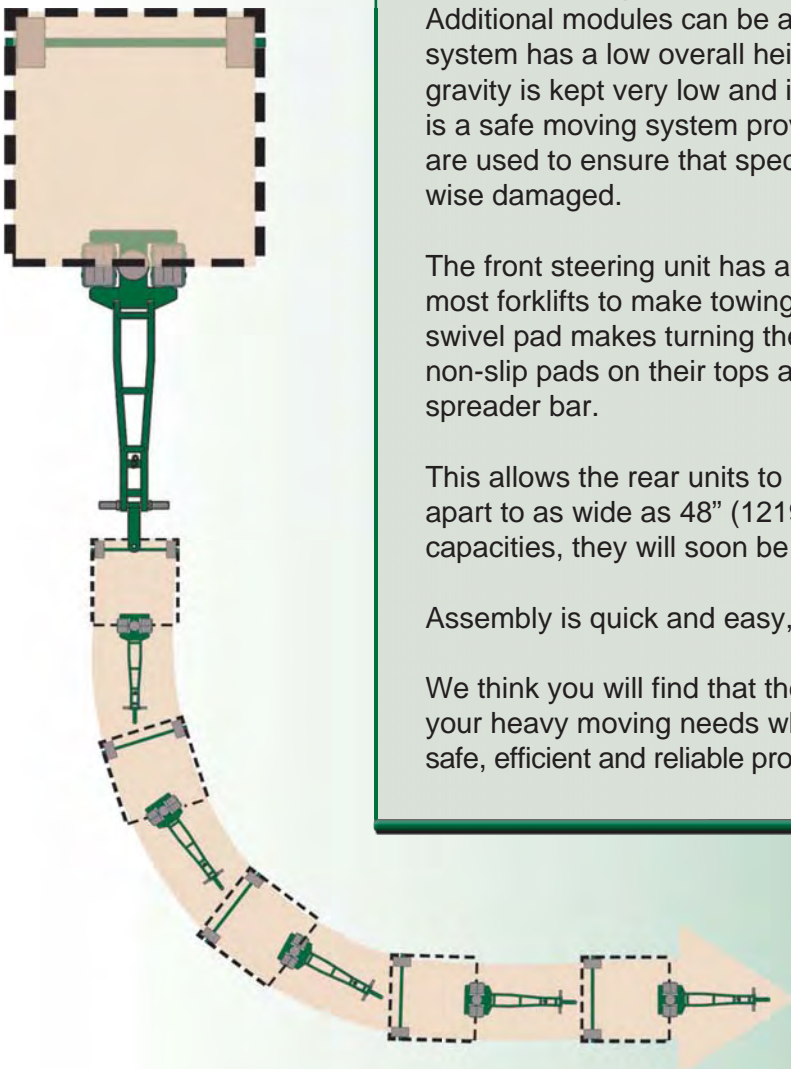

Introducing the 3-point moving system from **Hilman Rollers**:

### The **TRI-GLIDE**



The Tri-Glide 3-point moving system is a product designed for moving heavy loads over specially coated floors. Its name is derived from a combination of its 3 contact points, "Tri" and the

"Glide" or ease with which heavy loads can be moved across smooth floors. It is comprised of a front steering unit and two rear adjustable units. Additional modules can be added to further stabilize large, 3-point moving system has a low overall height of 4 inches. Because the load center of gravity is kept very low and is also spread over a generous area, the result is a safe moving system providing maximum floor protection. Nylon rolls are used to ensure that specially treated floors are not marred or otherwise damaged.

The front steering unit has a versatile handle, capable of integrating with most forklifts to make towing loads a viable option. A large, non-slip, swivel pad makes turning the unit easy. The adjustable rear units contain non-slip pads on their tops as well and are separated by means of a spreader bar.

This allows the rear units to be adjusted from a range on only a few inches apart to as wide as 48" (1219 mm). Currently available in 6, 12 and 18 ton capacities, they will soon be available in higher capacities.

Assembly is quick and easy, and requires no tools.

We think you will find that the Tri-Glide 3-point moving system will answer your heavy moving needs where floor protection is a concern. It is another safe, efficient and reliable product from the makers of **Hilman Rollers**.

#### Spreader Bar

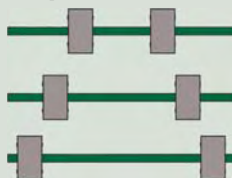

The rear units are kept aligned by a spreader bar. The rear dollies can be adjusted from a range of 10" to as much as 48" apart. Special lengths can be ordered.

# GLIDE

## 3-Point Heavy Moving Over All Types of Floors

### 6 TON HILMAN TRI-GLIDE ROLLER SYSTEM KTG-6N • KTG-6P • KTG-6S

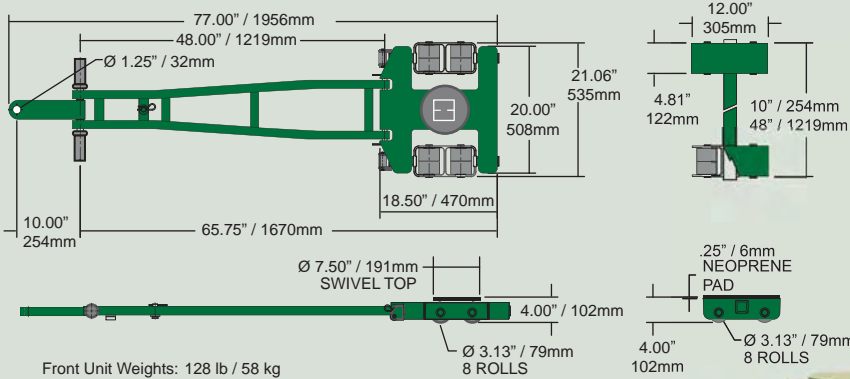

KTG-6N 6 Ton  
KTG-12N 12 Ton  
KTG-18N 18 Ton

#### Nylon Wheels

All Tri-Glide Moving systems come standard with Nylon Wheels. They are an ideal 'all-purpose' wheel that allows for good floor protection and favorable wear characteristics. These wheels will not 'set' if left under load (static) for a period of time.



KTG-6P 6 Ton  
KTG-12P 12 Ton  
KTG-18P 18 Ton

#### Polyurethane Wheels

Provide even better floor protection than their Nylon counterparts, though they are not as durable. A softer wheel, they provide excellent floor protection on tile floors.

### 12 TON HILMAN TRI-GLIDE ROLLER SYSTEM KTG-12N • KTG-12P • KTG-12S

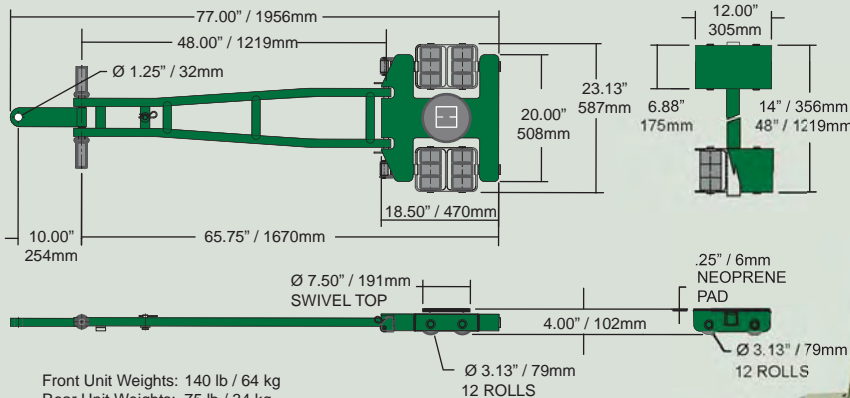

KTG-6S 6 Ton  
KTG-12S 12 Ton  
KTG-18S 18 Ton

#### Steel Wheels

Provide the best wear characteristics and is great for durable floors.

### 18 TON HILMAN TRI-GLIDE ROLLER SYSTEM KTG-18N • KTG-18P • KTG-18S

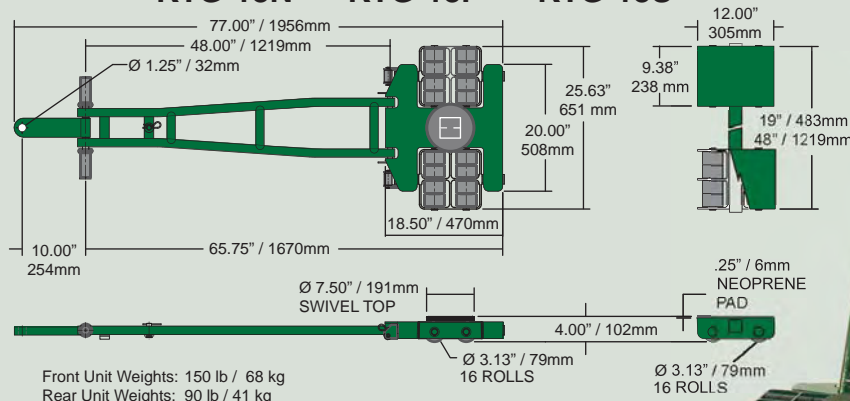

	KTG-6N KTG-6P KTG-6S	KTG-12N KTG-12P KTG-12S	KTG-18N KTG-18P KTG-18S
Load Capacity:	6 Ton	12 Ton	18 Ton
Wheels in Front Unit:	8	12	16
Wheels in Rear Unit:	8	12	16
Rear/Front Units Height:	4"	4"	4"
	101.6 mm	101.6 mm	101.6 mm
Handle Length:	48"	48"	48"
	1219.2 mm	1219.2 mm	1219.2 mm
Front Unit Width:	21.06"	23.13"	25.63"
	535 mm	588 mm	651 mm
Rear Unit Width:	4.81"	6.88"	9.38"
	122 mm	175 mm	238 mm
Bar + Rear Unit Width:	Maximum: 48" / 1219 mm)		
	Minimum: 2 x Rear Unit Width		
Front Unit Weights:	128 lb	140 lb	150 lb
	58 kg	64 kg	68 kg
Rear Unit Weights:	59 lb	75 lb	90 lb
	27 kg	34 kg	41 kg

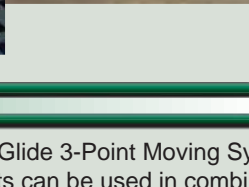
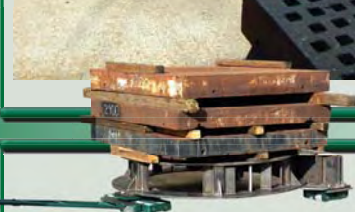

**Protects All Types of Flooring**

The Tri-Glide 3-Point Moving System is a truly versatile system- front and rear units can be used in combination to become a 4 or more Point moving system to accommodate capacity requirements or support long lengths and widths of the load.

Kit	Front Unit		Rear Unit		
<b>Tri-Glide with NYLON Wheels</b>					
KTG-6N	6 ton capacity	TG-6FN	3 ton capacity	TG-6RN	3 ton capacity
KTG-12N	12 ton capacity	TG-12FN	6 ton capacity	TG-12RN	6 ton capacity
KTG-18N	18 ton capacity	TG-18FN	9 ton capacity	TG-18RN	9 ton capacity
<b>Tri-Glide with POLY Wheels</b>					
KTG-6P	6 ton capacity	TG-6FP	3 ton capacity	TG-6RP	3 ton capacity
KTG-12P	12 ton capacity	TG-12FP	6 ton capacity	TG-12RP	6 ton capacity
KTG-18P	18 ton capacity	TG-18FP	9 ton capacity	TG-18RP	9 ton capacity
<b>Tri-Glide with STEEL Wheels</b>					
KTG-6S	6 ton capacity	TG-6FS	3 ton capacity	TG-6RS	3 ton capacity
KTG-12S	12 ton capacity	TG-12FS	6 ton capacity	TG-12RS	6 ton capacity
KTG-18S	18 ton capacity	TG-18FS	9 ton capacity	TG-18RS	9 ton capacity

### Configurations

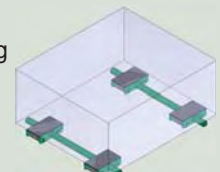

4-Point moving System  
Two Rear Units with Spreader Bars

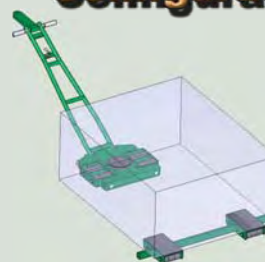

3-Point moving System  
One Front Unit + One Rear Unit  
with Spreader Bar

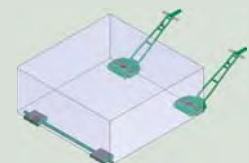

4-Point moving System  
Two Front Units + One Rear Unit  
with Spreader Bar

#### ONE YEAR LIMITED WARRANTY

We warrant each new roller sold by us to be free from manufacturing defects in normal service for a period of one (1) year commencing with delivery of the roller to the original user. Our obligation under this warranty is expressly limited at our option, to the replacement or repair at Hilman, Incorporated, Marlboro, New Jersey 07746 USA, or at a service facility designated by us, of such part or parts as inspection shall disclose to have been defective. This warranty does not apply to defects caused by damage or unreasonable use, including failure to provide reasonable and necessary maintenance, while in the possession of the consumer.

WE SHALL NOT BE LIABLE FOR CONSEQUENTIAL DAMAGES OF ANY KIND, including, but not limited to, consequential labor costs or transportation charges in connection with the replacement or repair of defective parts.

We make no warranty with respect to trade accessories. They are subject to the warranties of their manufacturers.

ANY IMPLIED OR STATUTORY WARRANTIES, INCLUDING ANY WARRANTY OF MERCHANTABILITY OR FITNESS FOR A PARTICULAR PURPOSE, ARE EXPRESSLY LIMITED TO THE DURATION OF THIS WRITTEN WARRANTY.

We make no other express warranty, nor is anyone authorized to make any on our behalf. Any and all claims arising against Hilman Rollers or subsidiaries or affiliated firms concerning the use of the Hilman Rollers shall be governed by the laws of the State of New Jersey in the USA.

12 Timber Lane • Marlboro NJ 07746 • USA  
 tel: (732) 462-6277 • fax: (732) 462-6355  
 web: HILMANROLLERS.COM • e-mail: sales@hilmanrollers.com  
 toll free (North America): 1-888-2-ROLL-IT