

3112/10

Gantrail Bolted Fixing

www.gantrail.com



The GANTRAIL 3112/10 adjustable crane rail clip is designed to fix light rails in the most arduous applications. It can withstand a horizontal force from the rail of 21kN (2.1 tonnes). Its low profile allows it to be used with cranes that are fitted with guide rollers.

SPECIFICATIONS:

MAX SIDE LOAD using Grade 8.8 bolt 21kN
10mm HORIZONTAL RAIL ADJUSTMENT

DIMENSIONS (mm):

REF NO.	X	Y (FULL NUT)	Y (THIN NUT)	Z	WEIGHT kg
3112/10/24	24	35	30	20	0.27
3112/10/31	31	35	30	20	0.29

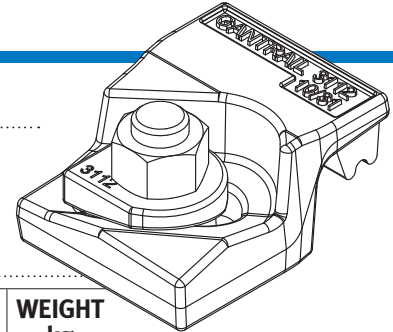

3112/10

FEATURES

- The proven design has been used successfully for many years throughout the world.
- The clip is bolted to the rail support.
- The two main parts are locked together on tightening the nut.
- A special vulcanised rubber block applies a controlled force to the rail.

COMPONENTS

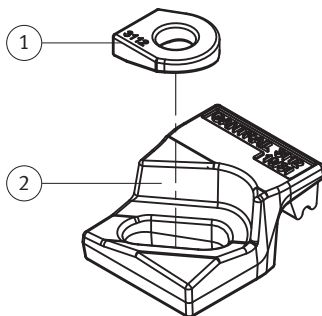

1. Special washer
2. Clip with integral rubber block

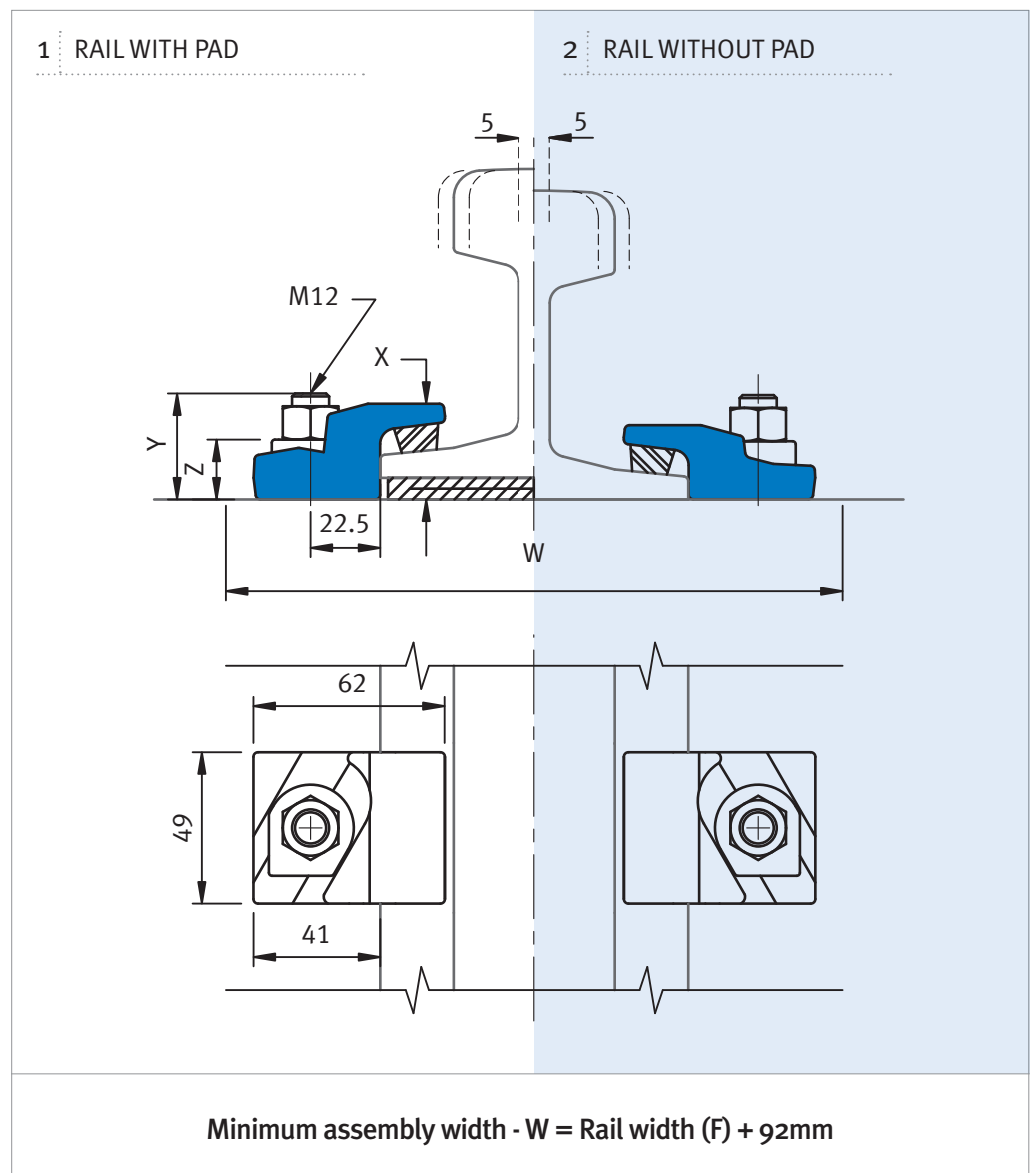

3112/10

Gantrail Bolted Fixing

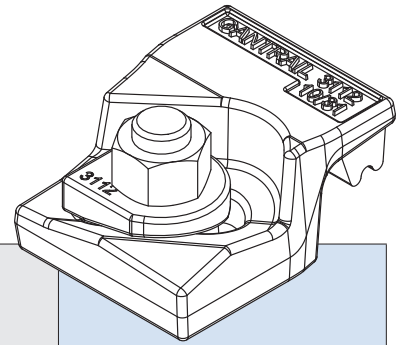

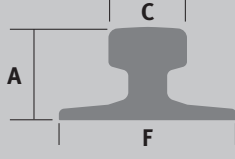
	F mm	C mm	A mm	1. CLIP REFERENCE FOR PAD MOUNTED RAIL	2. CLIP REFERENCE FOR RAIL WITHOUT PAD
A 45	125	45	55	3112/10/31	3112/10/24
S 7	50	25	65	3112/10/31	3112/10/24
S 10	58	32	70	3112/10/31	3112/10/24
S 14	70	38	80	3112/10/31	3112/10/24
S 18	82	43	92	3112/10/31	3112/10/24
S 20	82	44	100	3112/10/31	3112/10/24
S 24	90	53	115	3112/10/31	3112/10/24
ASCE 30	79	43	79	3112/10/31	3112/10/24
ASCE 40	89	48	89	3112/10/31	3112/10/24
ISCOR 22	95	50	95	3112/10/31	3112/10/24
9 kg	64	32	64	3112/10/31	3112/10/24
12 kg	70	43	70	3112/10/31	3112/10/24
15 kg	80	43	80	3112/10/31	3112/10/24
22 kg	94	51	94	3112/10/31	3112/10/24
JIS 12	70	38	70	3112/10/31	3112/10/24
JIS 15	79	43	79	3112/10/31	3112/10/24
JIS 22	94	51	94	3112/10/31	3112/10/24
15 kg BHP	79	43	79	3112/10/31	3112/10/24
22 kg BHP	94	51	94	3112/10/31	3112/10/24

THIS CLIP CAN BE USED FOR A WIDER SELECTION OF RAILS THAN ILLUSTRATED.

Please contact GANTRAIL for the full range of possible rails. All rails can be fastened with bolted or welded base clips.

GANTRAIL may change or improve their products and also alter specifications without notice.

INSTALLATION INSTRUCTIONS:

The hexagon headed fixing bolt can be inserted from above or below the supporting structure – see adjacent configurations.

If it is desired to fix the clip with a welded stud, this may be possible. Please consult GANTRAIL for guidance.

TIGHTENING TORQUE
Grade 8.8 bolt 85Nm

Please contact GANTRAIL for full installation instructions.

BOLT CONFIGURATIONS

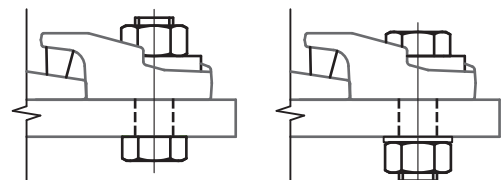

POSITIONING OF SPECIAL WASHER

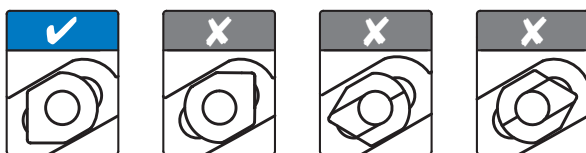

A world of crane rail expertise.

www.gantrail.com



Gantry Railing Ltd
Sudmeadow Road
Hempstead
Gloucester GL2 5HG
ENGLAND

Tel: +44 (0) 1452 300688
Fax: +44 (0) 1452 300198
E-mail: info@gantrail.com

Gantrail (Middle East) Ltd
P O Box 61428
Jebel Ali Free Zone
Dubai
United Arab Emirates

Tel: +971 4 8812 935
Fax: +971 4 8812 936
E-mail: gme@gantrail.com



3112/10/ET/06/10