

MAST BOOM LIFTS

MB20J/MB26J

DIMENSIONS	MB20J	MB26J
Max. working height	8.0m	10.0m
Max. platform height	6.0m	8.0m
Max. working outreach	2.6m	3.0m
Platform size	0.78m x 0.73m	0.78m x 0.73m
Overall width (A)	0.81m	1.0m
Stowed length (C)	2.43m	2.8m
Stowed height (B)	1.98m	1.98m
Ground clearance	100mm	100mm

PERFORMANCE		
Platform capacity (SWL)	215kg	215kg
Max. drive height	6.0m	8.0m
Max. drive speed (stowed)	3.3km/h	3.3km/h
Max. drive speed (elevated)	0.6km/h	0.6km/h
Jib length	1.02m	1.4m
Jib arc	130°	120°
Mast rotation (non-continuous)	360°	360°
Raise/lower time	54/26sec	56/27sec
Gradeability	25%	25%
Inside turning radius	0.3m	0.3m
Outside turning radius	1.85m	2.1m
Tyres	343-285 non-marking	
Drive system	electro/hydraulic	

POWER	
Power source	4 x 6V x 375 AH batteries

WEIGHT		
Gross weight	2,590kg	2,660kg

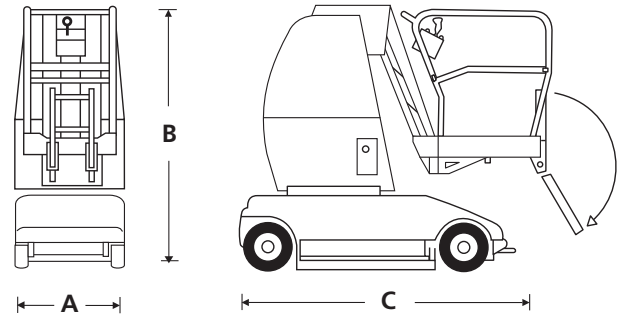

STANDARD FEATURES

- Proportional one-hand controls
- Ultra-tight inside turning radius
- Tilt alarm
- Power line to platform (no sockets)
- 2 persons + equipment capacity indoors
- 1 person + equipment capacity outdoors
- Solid non-marking tyres
- Ground control station
- Self-seeking automatic charger
- Automated battery top up
- CE approved

OPTIONS

- Special paint colours
- Flashing amber beacon
- Environmental green oil

WORKING ENVELOPE

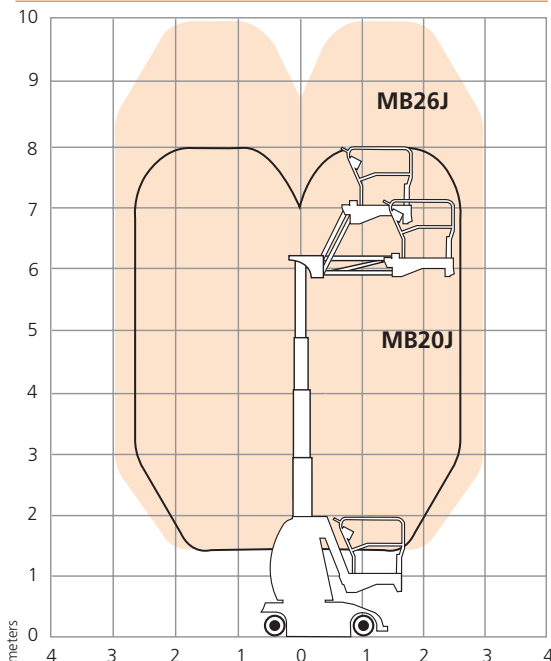

snorkel www.snorkellifts.com

Vigo Centre, Birtley Road,
Washington, Tyne & Wear,
NE38 9DA, U.K.

t: +44 (0) 845 1550 057

e: sales@snorkellifts.com