

ARTICULATED BOOM LIFT

A38E

DIMENSIONS	A38E
Max. working height	13.5m
Max. platform height (A)	11.5m
Max. working outreach	6.1m
Clearance height at max. outreach	5.4m
Platform size (outside)	0.6m x 1.2m
Overall width (B)	1.50m
Overall length (C)	4.04m
Stowed height (D)	2.0m
Ground clearance	150mm

PERFORMANCE	
Platform capacity (SWL)	215kg
Max. drive speed (stowed)	4.0km/h
Max. drive speed (elevated)	0.7km/h
Raise/lower time	83/68 sec
Gradeability	36%
Inside turning radius	0.4m
Outside turning radius	2.4m
Tyres	22 x 9 16 non-marking
Controls	smooth, one-hand proportional controls
Drive system	direct drive DC

POWER	
Power source	8 x 6V, 220Ah batteries

WEIGHT	
Gross weight	3850kg

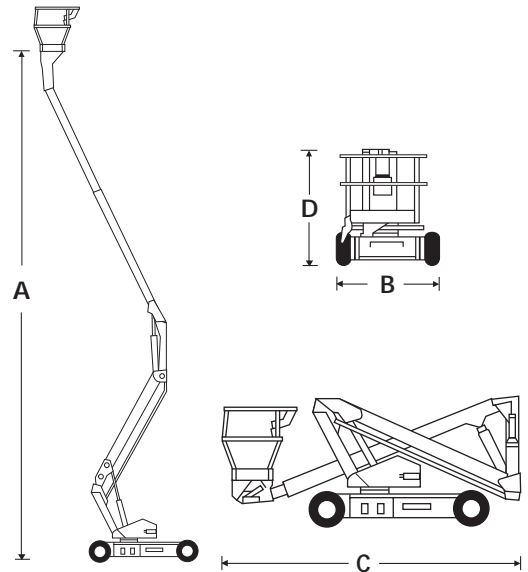

STANDARD FEATURES

- Proportional one-hand controls
- Minimal front boom overhang
- Ultra-tight inside turning radius
- Power line to platform (no sockets)
- Tilt alarm
- Large, two person platform
- Direct DC drive parallel wired wheel motors
- Non-marking tyres
- Duplicate boom controls at ground level
- CE approved

OPTIONS

- Special paint colours
- Flashing amber beacon
- Manual platform rotator
- Environmental green oil

WORKING ENVELOPE

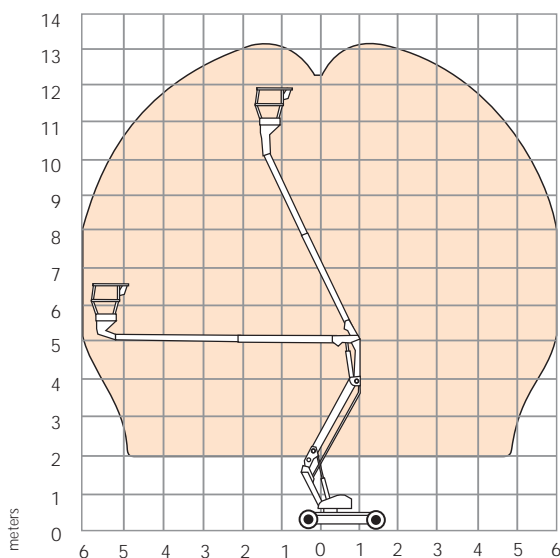

snorkel

Vigo Centre, Birtley Road,
Washington, Tyne & Wear,
NE38 9DA, U.K.

t: +44 (0) 845 1550 057

e: sales@snorkellifts.com

www.snorkellifts.com